

# Lost Foam Process

The Lost Foam Process enables the illustration of complex cast part geometrics by using positive styrofoam models. When filling, the binder-free molding sand must spotlessly and perfectly cover any cavities of the styrofoam part. This also applies to multi-angled cavities.

Due to these complex requirements, the core piece of the Lost Foam Plant is the compaction table. Using common vibration tables is not possible, as they only provide a vertically oriented vibration motion. For the perfect filling of horizontal cavities, a defined, horizontally vibrating motion is required in order to achieve the desired forward motion of the sand inside the cavity.

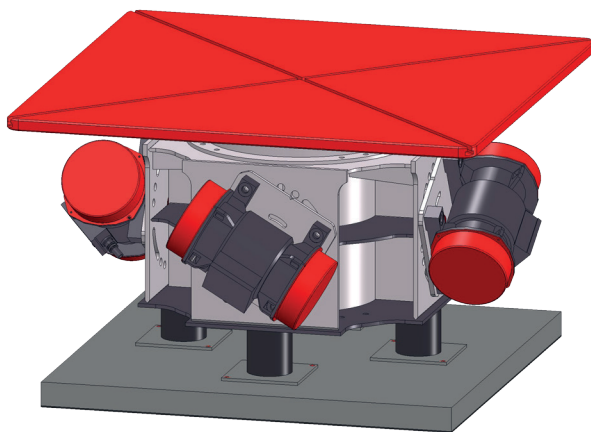

### The Multi Dimensional Compaction Table:

As a result, JOEST has developed a special vibration table – the Multi Dimensional Compaction Table. Using several unbalance motors, which are controlled in real time, this vibration table is capable of freely varying the vector on the vibration on the X, Y or Z axis, including angle, frequency and vibration amplitude. A vibration and self-resonance free start up from zero to the desired frequency is also guaranteed.

### Technical Data:

**Type:** 1.600 x 1.600

**Start Up Sequence:** Without resonances

**Vibrating Frequency:** Electronically adjustable

**Vibrating Vector in X-direction:** Electronically adjustable

**Vibrating Vector in Y-direction:** Electronically adjustable

**Vibrating Vector in Z-direction:** Electronically adjustable